

BLAKEBOROUGH® CAGE & TOP GUIDED VALVES



Trillium Flow Technologies™ Control & Choke Valves provide a wide range of control valves for the process industry. These include severe service, choke, desuperheating and turbine bypass applications.

Our world-wide reputation is based on engineering excellence applied to a comprehensive range of specialist products and effective customer support.

A PROVEN TRACK RECORD

We have extensive references and a proven track record in the supply of valves across a number of key industries.

Our valves are industry renowned brands, each with an established reputation for quality engineering and reliability.

VALVE TESTING

All pressure containing items are hydrostatically tested, seat leakage tested and functionally tested.

We can also perform gas, packing emission, cryogenic and advanced functional testing, as well as seismic testing for nuclear applications.

MATERIAL TESTING

- Non-destructive examination by radiography, ultrasonics, magnetic particle and liquid penetrant
- Chemical analysis by computer controlled direct reading emission spectrometer
- Mechanical testing for tensile properties at ambient and elevated temperatures, bend and hardness testing. Charpy testing at ambient, elevated and sub-zero temperatures

AFTERMARKET SOLUTIONS

Our valve aftermarket solutions are based on our engineering heritage, applying our OEM knowledge and expertise to maintenance strategies, life extension and upgrade projects.

CONTENTS

BV520 Single seat control valve	3
General description	4
Cv and dimensions	5
Weights & specification	6
BV502 & BV503 control valves	7
General description	8
Trim design	9
Valve selection guideline	10
Cage Trim Control valves	13
General description	14
Cage designs	16
Plug designs	17
Bonnet forms	28
Characteristics	29



Trillium Flow Technologies UK Limited purpose built factory at Elland



Trillium Flow Technologies, South Korea

QUALITY ASSURANCE

Trillium Flow Technologies™ is qualified to industry standards and working practices including:

- ASME BPVC Section III (N and NPT Stamp)
- NQA-1 Quality system
- 10CFR50 App. B
- 10CFR50 Part 21
- RCC-E
- RCC-M
- CSA Z299
- Performance testing and qualification to:
 - ASME QME-1
 - ASME B16.41
 - IEEE 323
 - IEEE 344
 - IEEE 382
- ISO 9001:2008
- ISO 14001
- PED 97/23/CE
- API Q1 TO API LICENCES:
 - API 6D (6D-0182)
 - API 6A (64-0445)
- OHSAS 18001
- ATEX 94/9/CE
- Lean manufacturing practices

ATWOOD & MORRILL®
Engineered Isolation & Check Valves

BATLEY VALVE®
High Performance Butterfly Valves

RED POINT®
Tailor-Made Valves

BLAKEBOROUGH®
Control & Severe Service Valves

HOPKINSONS®
Parallel Slide Gate & Globe Valves

SARASIN-RSBD®
Pressure Safety Devices

SEBIM®
Nuclear Valves

TRICENTRIC®
Triple Offset Butterfly Valves

Portfolio of engineered service solutions and aftermarket support



BV520 SINGLE SEAT CONTROL VALVE

DESIGN FEATURES

- Contour trim
- Wide range of trim options
- High stability
- Easy maintenance
- High Cv
- Unbalanced

PRESSURE RATING

- Class 150 to 600 Equivalent metric ratings

SIZES

- 40mm to 150mm (1 1/2" to 6")

TRAVELS

- 28.5mm to 57mm

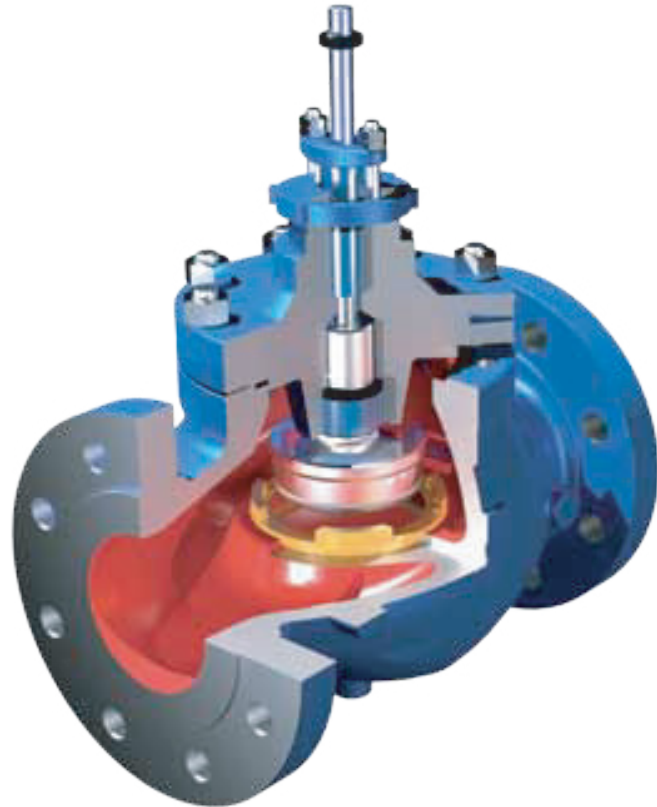

DESCRIPTION

The Trillium Flow Technologies™ BV520 series valves are a top guided unbalanced design and with single-ported design configuration. The flow characteristic of trims can be selected as linear, equal percentage or quick open. The simple construction and flexible trims selection of Series BV520 can reduce the maintenance costs and make it easy to change the trims. The valves are suited to a wide range of general process applications, such as water, steam, oil, gases and the majority of chemical services.

MAIN DESIGN CODE/STANDARD

- ASME FCI 70-2 – Control Valve Seat Leakage
- ASME B16.25 – Butt Welding Ends
- ASME B 16.5 – Pipe Flanges & Flange Fittings
- ASME 16.34 – Valves-Flanged, Threaded & Welding End
- NACE MR 0175 (ISO 15156) – Valve Materials (Option)
- IEC 60534 Industrial Process Control Valves

DESIGN FEATURES

- Top guided
- Wide range of trim options
- High capacity
- Excellent rangeability
- High integrity closure
- Optional flow characteristic trim

PRESSURE RATING

- Class 150LB to 600LB
- PN16 to PN100

SIZES

- 40mm to 150mm (1 1/2" to 6")

END CONNECTIONS

- Flanged
- Butt weld
- Socket weld
- Screwed (1 1/2" to 2")

CV VALUE

- 13 to 450

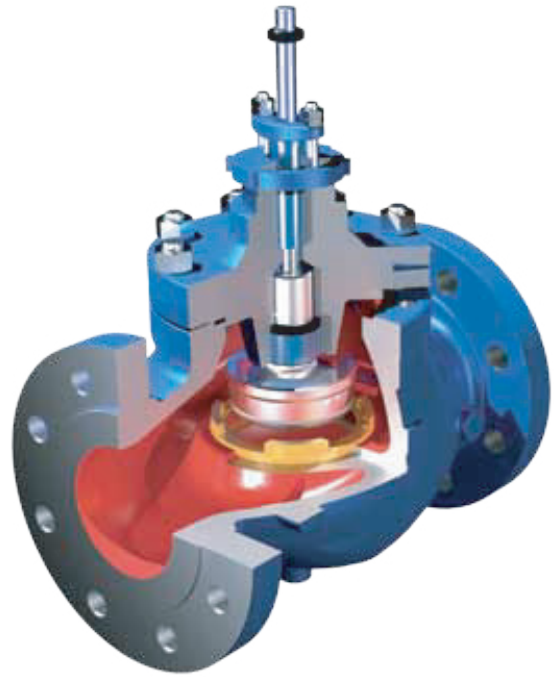

RANGEABILITY

- 50:1

LEAKAGE CLASS

- Class IV, V or VI per customer's request

BODY MATERIAL

- Carbon Steel
- Stainless Steel
- Other materials on request

VALVE TYPE

- Globe Type

ACTUATOR TYPE

- Pneumatic Actuator
- Electric Actuator
- Manual Operation

TABLE 1 – DESIGN CV VALUES

CHARACTERISTIC	SIZE		TRAVEL	FULRATE	MIDRATE	LORATE
	IN	MM	MM			
Linear	1 1/2	40	28.5	30	20	13
	2	50	28.5	52	30	20
	3	80	38	110	85	52
	4	100	38	190	110	85
	6	150	57	390	285	190
Equal %	1 1/2	40	28.5	28	20	13
	2	50	28.5	52	28	20
	3	80	38	115	76	52
	4	100	38	170	115	76
	6	150	57	340	240	170
Quick Open1	1 1/2	40	28.5	30	25	15
	2	50	28.5	58	30	25
	3	80	38	125	80	58
	4	100	38	230	125	80
	6	150	57	450	340	230

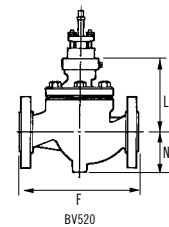

TABLE 2 – VALVE DIMENSIONS

SIZE		RATING	F			L		N
IN	MM		FLANGED	BUTT WELD	THREADED/ SOCKET WELD	STANDARD BONNET	NORMALISING BONNET	
1 1/2	40	150	222	251	251	149	274	89
		300	235					
		600	251					
2	50	150	254	286	286	149	274	92
		300	267					
		600	286					
3	80	150	318	337		185	298	111
		300	318					
		600	337					
4	100	150	352	394		191	304	135
		300	368					
		600	394					
6	150	150	451	508		256	372	168 172
		300	473					
		600	508					

TABLE 3 – VALVE WEIGHT (KG)

SIZE		RATING	FLANGED		BUTT/SOCKET WELD	
IN	MM		STANDARD BONNET	NORMALISING BONNET	STANDARD BONNET	NORMALISING BONNET
1½	40	150	19	22	17	20
		300	21	25	17	21
		600	22	25	17	20
2	50	150	22	25	20	23
		300	23	27	20	24
		600	25	29	20	24
3	80	150	45	47	39	41
		300	49	50	40	41
		600	53	53	41	41
4	100	150	62	64	58	60
		300	70	72	58	60
		600	80	81	57	58
6	150	150	120	122	120	122
		300	138	140	120	122
		600	168	169	125	126

TABLE 4 – TYPICAL VALVE MATERIALS (OTHER MATERIALS AVAILABLE ON REQUEST)

ITEM	DESCRIPTION	CARBON STEEL	STAINLESS STEEL
1	Body	WCB	CF8M
2	Bonnet	A105	CF8M
3	Seat Ring	316L+Stellite	316L+stellite
4	Body Gasket	316L+Graphite	316L+Graphite
5	Body Stud	B7	B8
6	Body Stud Nut	2H	8
7	Clamp Nut	CF8M	CF8M
8	Packing Bush	Carbon EY306BY	Carbon EY306BY
9	Valve Plug	316L+Stellite	316L+stellite
10	Plug Stem Pin	316L Stainless	316L Stainless
11	Plug Stem	316L Stainless	316L Stainless
12	Guide Bush	440C or Stellite	440C or Stellite
13	Packing Flange	CF8M	CF8M
14	Packing Flange Stud	A4-80	A4-80
15	Packing Flange Nut	A4-80	A4-80
16	Stem Nut	A4-80	A4-80
17	Packing Follower	316L Stainless	316L Stainless
18	Packing Set	PTFE or Graphite	PTFE or Graphite

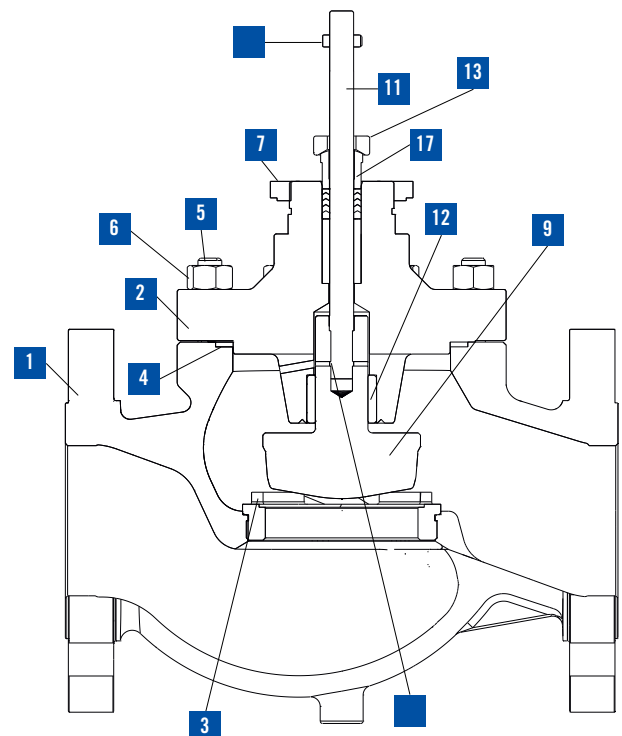

BV502 & BV503 PROCESS CONTROL VALVES

DESIGN FEATURES

- Top cage guided
- Wide range of trim options
- High stability
- Easy maintenance

PRESSURE RATING

- Class 150 to 4500 Equivalent metric ratings

SIZES

- 15mm to 25mm (1/2" to 1")

TRAVELS

- 10mm to 25mm (3/8" to 1")

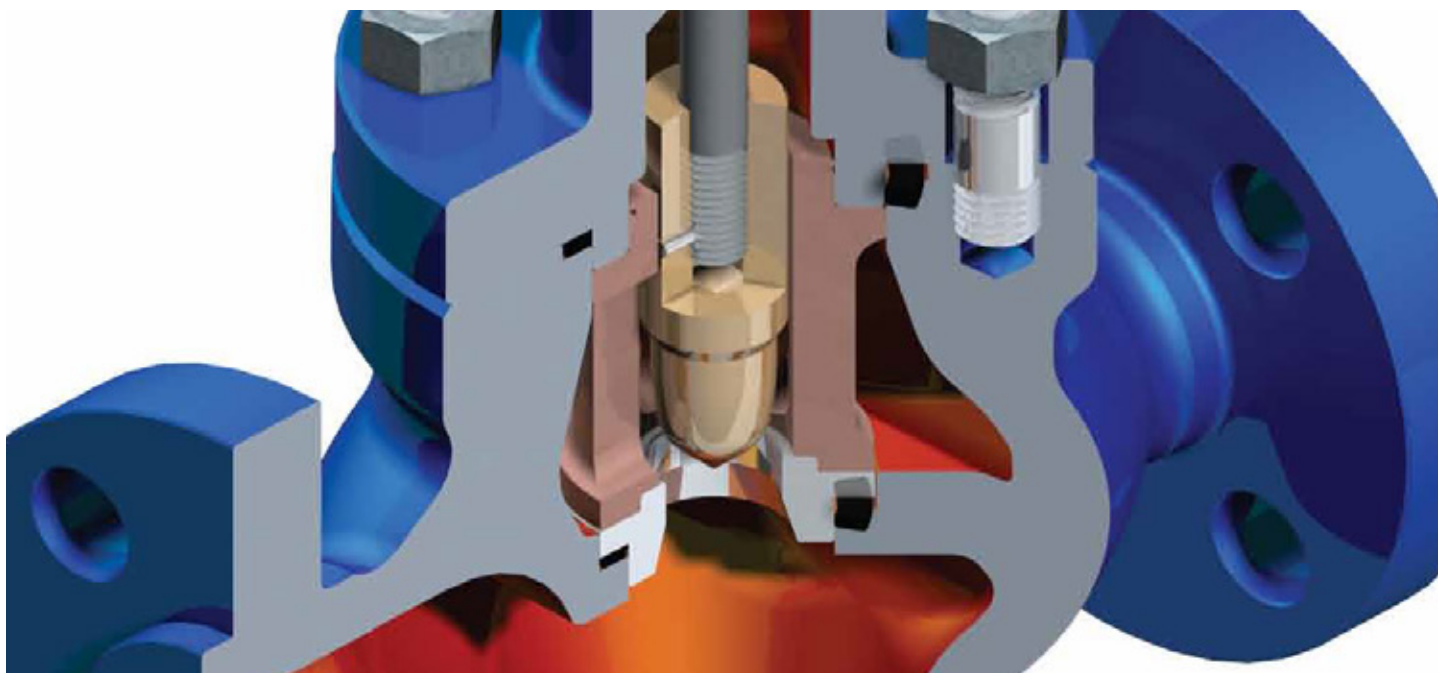
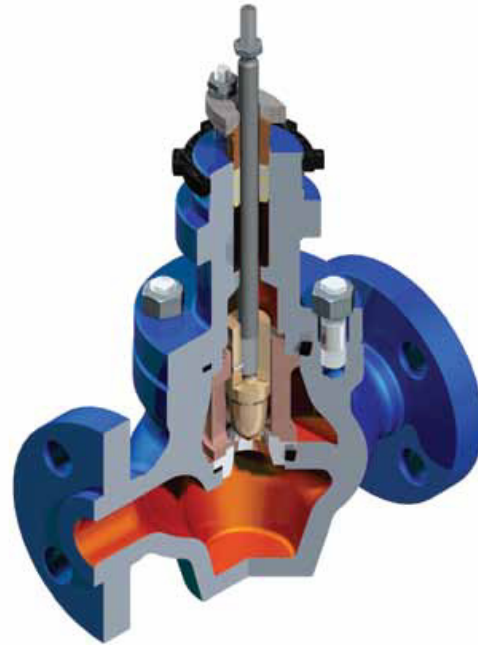

DESCRIPTION

This versatile range of globe and angle valves available in sizes 15mm to 25mm (1/2" to 1") offer a wide variety of trim selections to suit all flow conditions in a non-balanced construction. The body design can be supplied in cast or forged materials.

There is a wide range of standard and high duty trims available that can be fitted within the same valve body. Flow characterisation is determined by the shape of the valve plug, or in the 'Multiflow' trim, a radial pattern of holes in the cage is arranged to give the required valve characteristic.

At the enquiry stage Trillium Flow Technologies™ will consider the most suitable combination of valve components for each application. Pressure drop, noise, potential for cavitation are all considered to give the most cost effective solution for the particular application. Parts substitution, internal inspection and maintenance can be performed with minimum trouble, the essential working components being removable while the body remains in the pipe line.

BODY

- A choice of globe or angle patterns is available
- BV502 Globe Body
- BV503 Angle Body

BODY MATERIALS

The valves can be produced in most alloys. Standard cast body materials are:-

- Carbon steel; Grade WCB, WCC, LCC and LCB
- Monel
- Stainless steel; Grade 316/304/347
- Aluminium Bronze
- Chrome moly steel; Grade WC5, WC6 & WC9
- Hastelloy B/C
- Duplex
- Most other materials can be produced

MAIN DESIGN STANDARDS

- ASME B16.34 – Valves-Flanged, Threaded & Welding End
- ASME FCI 70-2 – Control Valve Seat Leakage
- ASME B16.25 – Butt Welding Ends
- ASME B16.5 – Pipe Flanges & Flange Fittings
- NACE MR-01-75 (ISO15156) Valve Materials
- BS4504 – Circular Flanges for Pipes, Valves & Fittings
- EN12516 – Industrial Valves Shell Design Strength

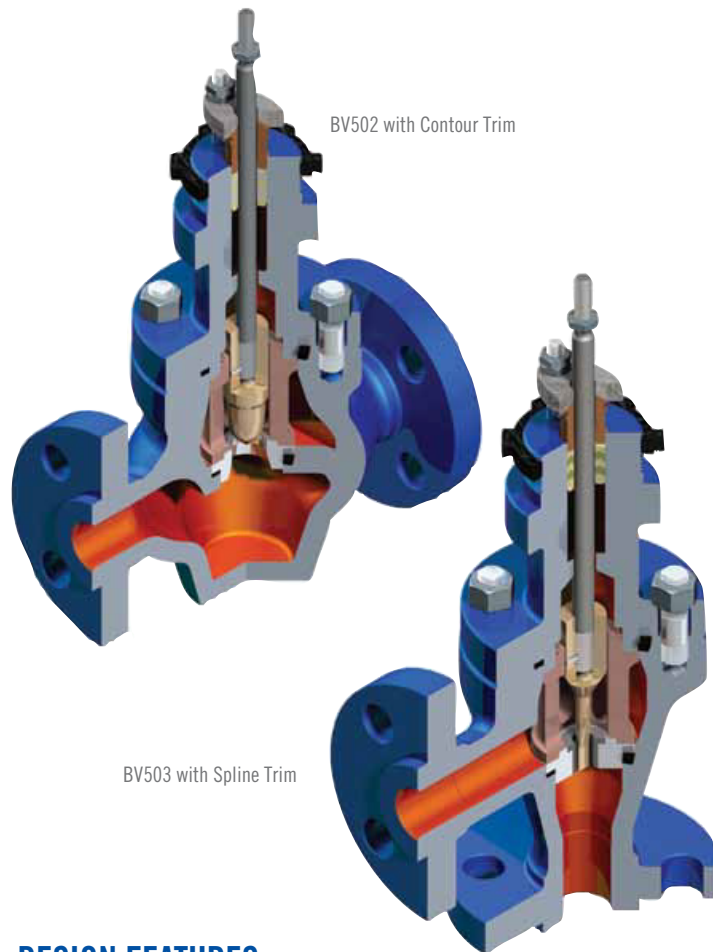

BV502 with Contour Trim

BV503 with Spline Trim

DESIGN FEATURES

- Top cage guided
- Wide range of trim options
- High stability
- Easy maintenance

PRESSURE RATING

- Class 150 to 4500 Equivalent metric ratings

SIZES

- 15mm to 25mm (1/2" to 1")
- End connection sizes 40mm (1 1/2") & 50mm (2") can be supplied

TRAVELS

- 10mm to 25mm (3/8" to 1")

END CONNECTIONS

- Flanged
- Butt weld
- Socket weld
- Screwed
- Hubbed
- Ring Type Joint (RTJ)

TRIM DESIGN

CONTOUR

The contour trim is suitable for most flow applications and is provided as standard in most valves. The valve characteristic is determined by the contour of the plug head. The contour trim is available in eight trim sizes with equal percentage, linear or quick opening characteristics. The trim seating is metal to metal or for tight shut-off a soft face design is available.

SPLINE

The spline trim is designed specifically for accurate control of very small flows. The design consists of a long parallel nosed plug with an accurately cut “V” notch cut down the centre. The linear movement of the valve plug exposes a variable amount of the notch to the flow. The plug head shank is usually made from stellite or other hard wearing materials for galling resistance and to prevent erosion of the plug tip. The actual characteristic derived from the “V” notch is modified equal percentage. The spline trim is available in either metal to metal design or where bubble tight shut off is required a soft face is fitted.

MULTI-FLOW (SINGLE STAGE OF PRESSURE DROP)

In this design flow is broken up into multiple jets by a number of radial holes drilled in the cage. The flow is conventionally from outside to inside the cage so that jet impingement/high turbulence levels are controlled within the confines of the valve cage. The flow jets impinge together in the centre of the cage bore producing a more stable downstream flow, this in turn reduces the effect of large scale separation thus producing a smaller scale turbulence structure in the valve outlet. This results in a reduction in acoustic efficiency and changes the power spectrum of the generated noise both of which contribute to noise level reduction of between 15 and 20 dBA, compared to a contoured trim valve.

2 & 3 STAGE PRESSURE LETDOWN TRIM

These trim designs are suited to applications where a high degree of pressure letdown is required to eliminate cavitation on low flow applications. The trim is designed so that flow passes through each stage of the trim. The design requires a very tight tolerance between the plug and seat to eliminate anular flow between the plug and seat.

BODY PROTECTION UNIT (DIFFUSER)

Is specified on globe valves where a high pressure across the valve leads to high velocity jet flow from the trim impinging directly onto the valve body wall. The seat diffuser deflects the jet away from the body wall towards the valve outlet. The seat diffuser is constructed of hardened steel which is more resistant to the effects of jet impingement than the valve body wall. This feature is particularly useful on flashing flows where high velocity two phase flows can lead to body erosion.



Contour trim



Soft face contour trim

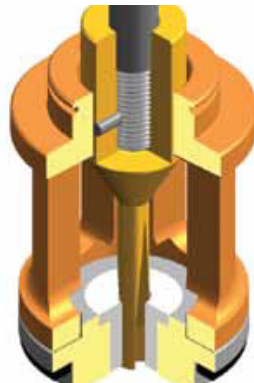

Spline



Multi-flow trim



Spline with diffuser

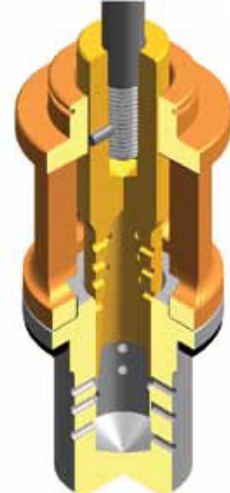

2-stage trim with diffuser



3-stage trim with diffuser

VALVE SELECTION GUIDELINE

VALVE FLOW CO-EFFICIENT

All valves are sized using the valve flow co-efficient, Cv, in accordance with ISA 75.01.01 as detailed in the Weir sizing and selection manual. Design Cv values are given in table 5.

BODY SELECTION

The valve body size and style is selected on the basis of supporting the selected trim design and design Cv.

In addition consideration is made of the velocity and the required pressure drop application. Liquid velocities are limited mainly due to erosion considerations, whereas gas/vapour flow velocities are limited for trim stability noise and vibration considerations.

TRIM SELECTION

The selection criteria of the valve trim ranges from valve flow co-efficient, rangeability, pressure drop, cavitation, flashing and noise consideration. The Trillium Flow Technologies sizing and selection manual details the various calculation methods and selection limitations for each trim design.

TABLE 1 – STANDARD TRIM MATERIAL COMBINATIONS

TRIM TYPE	PLUG	SEAT	CAGE TEMP 400°C (750°F) MAX	CAGE TEMP 401°C (751°F) & ABOVE
Contour	316 ST.ST.	316 ST.ST.	17-4PH ST.ST. Hardened	420 ST.ST. Hardened
	316 ST.ST. with Stellite face	316 ST.ST. with Stellite face		
Spline	316 ST.ST. with full Stellite	316 ST.ST. with full Stellite		
Step Cone	316 ST. ST. with Stellite	316 ST. ST. with Stellite		
Multi-flow	316 ST.ST. with Stellite face	Integral with guide		
Soft face	316 ST.ST.	316 ST.ST. with PTFE		
Staged trim	316 ST.ST. with Stellite face	316 ST.ST. with Stellite face		
All trims	Tungsten Carbide with ST.ST.	Tungsten Carbide with ST.ST.		

For services below -35°C (-30°F), all 316 ST. ST. construction with PTFE seals.

The above table shows standard ST. ST. combination. Many other materials can be used depending on the application.

TABLE 2 – RECOMMENDED LIMITING INLET VELOCITIES FOR CONTROL VALVES

VALVE SIZE MM IN	LIQUID M/S	LIQUID FT/S	STEAM OR GAS M/S	STEAM OR GAS FT/S	MAX OUTLET (STEAM OR GAS)
15,20 & 25 ½, ¾ & 1	13.5	45	115	375	0.65 X SONIC

Note: 0.3 sonic for low noise applications

TABLE 3 – RANGEABILITY

VALVE SIZE MM IN	CONTOUR (METAL & SOFT FACED)	SPLINE (METAL & SOFT FACED)	STEP CONE	MULTI-FLOW	STAGE TRIM
15,20 & 25 ½, ¾ & 1	50.1	100.1	50.1	30.1	100.1

Note: Control at openings of less than 5% is not recommended for prolonged periods

TABLE 4 – CONTROL VALVE LEAK RATES IN ACCORDANCE WITH ASME/FCI 70-2 (IEC 60534-4)

ASME LEAKAGE CLASS	TRIM STYLE	MAXIMUM ALLOWABLE LEAKAGE
Class IV	Metal faced	0.01% of rated capacity
Class V	Metal faced - lapped seats	0.0005ml/min of water per inch of port per PSI pressure drop
Class VI	Soft seat	Bubble tight

TABLE 5 – DESIGN CV VALUES

VALVE SIZE	CONTOUR TRIM				VALVE SIZE	SPLINE/M SPLINE			STEP CONE			MULTI-FLOW				
	TRIM SIZE	QUICK OPEN	LINEAR & =%	TRAVEL		TRIM SIZE	MOD=%	TRAVEL	TRIM SIZE	LINEAR	TRAVEL	TRIM SIZE	=%	LINEAR	TRAVEL	
	DC1	13.5	13.5	25mm (1")	All sizes	MC01	3.2	Standard spline 25mm (1") Multi-stage spline 19mm (3/4")	SC4	4.5	25mm (1")	MF1	12	12	12	
	DC2		10			MC00	2		SC5	3		MF2	8	8	25mm (1")	
	DC3	7	7			MC0	1.26		SC6	1.7		MF3	5.6	5.6	25mm (1")	
	DC4	4.5	4.5			MC1	0.63		SC7	1		MF4	3.2	3.2	19mm (3/4")	
	DC5		3			MC2	0.4		SC8	0.63						
	DC6		1.7			MC3	0.25		SC9	0.4						
	DC7		1			MC4	0.16		SC10	0.25						
	DC9		0.4			MC5	0.1									
				Not available as M/Spline	MC6	0.063										
					MC7	0.04										
					MC8	0.025										
					MC9	0.016										
					MC10	0.01										
					MC11	0.0063										
					MC12	0.004										
				MC13	0.0025											
				MC14	0.0016											
				MC15	0.001											

TABLE 6 - VALVE WEIGHTS (KG)

VALVE SIZE & BODY STYLE	BONNET TYPE	UP TO 600 (PN100) RTG		UP TO 1500 (PN250) RTG		UP TO 2500 (PN420) RTG		UP TO 4500 RTG	
		FLG	B.W	FLG	B.W	FLG	B.W	FLG	B.W
Up to 25mm (1") Cast	Standard	16	8	18	8	NA	NA	NA	NA
	Normalising	19	11	20	11	NA	NA	NA	NA
	Bellows	25	17	26	17	NA	NA	NA	NA
	Cryogenic	24	16	25	26	NA	NA	NA	NA
Up to 25mm (1") Forged	Standard	26	18	28	18	30	20	35	25
	Normalising	29	21	30	21	32	23	37	28
	Bellows	35	17	36	27	NA	NA	NA	NA
	Cryogenic	34	26	35	26	37	28	42	32

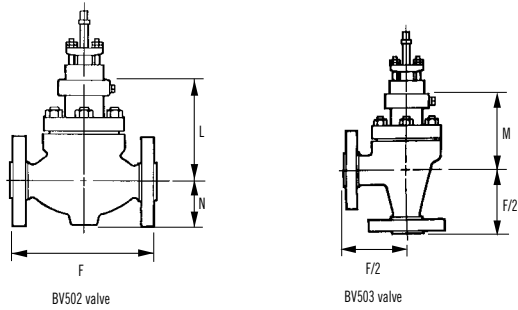

TABLE 7 – VALVE DIMENSIONS

NOMINAL VALVE SIZE MM IN	CAST BODIES															
	UP TO ASME 300 R.F.(PN40)	ASME 600 R.F. & RTJ (BS PN 64 & 100)	ASME 900 & 1500 R.F. & RTJ (PN 160 & 250)	BUTT WELD UP TO ASME 600 (PN 250)		BUTT WELD ASME 900 & 1500 (PN 160 & 250)		STANDARD		NORMALISING		BELLOWS		CRYOGENIC		N (MAX)
	F	F	F	F	F/2	F	F/2	L	M	L	M	L	M	L	M	
15	191	203	273	187	105	197	105	151	130	206	185	333	311	375	406	75 3
½	7 ½	8	10 ¼	7 ⅝	4 ⅞	7 ¼	4 ⅞	65	⅝	8 ⅞	7 ⅞	13 ⅞	12 ¼	14 ¾	16	
20	194	206	273	187	105	197	105	151	130	206	185	333	311	375	406	
¾	7 ⅝	8 ⅞	10 ¼	7 ⅝	4 ⅞	7 ¼	4 ⅞	6	5 ⅞	8 ⅞	7 ⅞	13 ⅞	12 ¼	14 ¾	16	
25	197	210	273	187	105	197	105	151	130	206	185	333	311	375	406	
1	7 ¾	8 ¾	10 ¾	7 ⅝	4 ⅞	7 ¼	4 ⅞	6	5 ⅞	8 ⅞	7 ⅞	13 ⅞	12 ¼	14 ¾	16	
40 x 25 x 40	235	251	305	251	127	305	152	151	130	206	185	333	311	375	406	
1½ x 1 x 1 ½	9 ¼	9 ⅞	12	9 ⅞	5	12	6	6	5 ⅞	8 ⅞	7 ⅞	13 ⅞	12 ¼	14 ¾	16	
50 x 25 x 50	267	286	340	286	143	337	168	151	130	206	185	333	311	375	406	
2 x 1 x 2	10 ½	11 ¼	13 ⅝	11 ¼	5 ⅞	13 ¼	6 ⅞	6	5 ⅞	8 ⅞	7 ⅞	13 ⅞	12 ¼	14 ¾	16	

Note: Flange valves are generally in accordance with ISA 75.08.06 and ISA 75.08.01

TABLE 8 – VALVE DIMENSIONS

NOMINAL VALVE SIZE MM IN	FORGED BODIES										
	UP TO INCL. ASME 1500 R.F. & RTJ (PN40)	ASME 2500 R.F. & RTJ (PN 420)	BUTT WELD UP TO ASME 2500 (PN 420)		BUTT WELD ASME 4500		STANDARD		NORMALISING		N (MAX)
	F	F	F	F/2	F	F/2	L	M	L	M	
15	238	318	318	160	330	165	228	228	283	283	85 3 ⅞
½	9 ⅞	12 ½	12 ½	6 ⅞	13	6 ½	9	9	11 ⅞	11 ⅞	
20	238	318	318	160	330	165	228	228	283	283	
¾	9 ⅞	12 ½	12 ½	6 ⅞	13	6 ½	9	9	11 ⅞	11 ⅞	
25	238	318	318	160	330	165	228	228	283	283	
1	9 ⅞	12 ½	12 ½	6 ⅞	13	6 ½	9	9	11 ⅞	11 ⅞	
40 x 25 x 40	318	318	318	160	330	165	228	228	283	283	
1½ x 1 x 1 ½	12 ½	12 ½	12 ½	6 ⅞	13	6 ½	9	9	11 ⅞	11 ⅞	
50 x 25 x 50	318	318	318	160	330	165	228	228	283	283	
2 x 1 x 2	12 ½	12 ½	12 ½	6 ⅞	13	6 ½	9	9	11 ⅞	11 ⅞	

Note: Flange valves are generally in accordance with ISA 75.08.06 and ISA 75.08.01

BV500/1 & BV990/2 PROCESS CONTROL VALVES

DESIGN FEATURES

- Cage guided
- Wide range of trim options
- High stability
- Easy maintenance

PRESSURE RATING

- Class 150 to 4500
- PN10 to PN640

SIZES

- 40mm to 900mm (1 1/2" to 36")

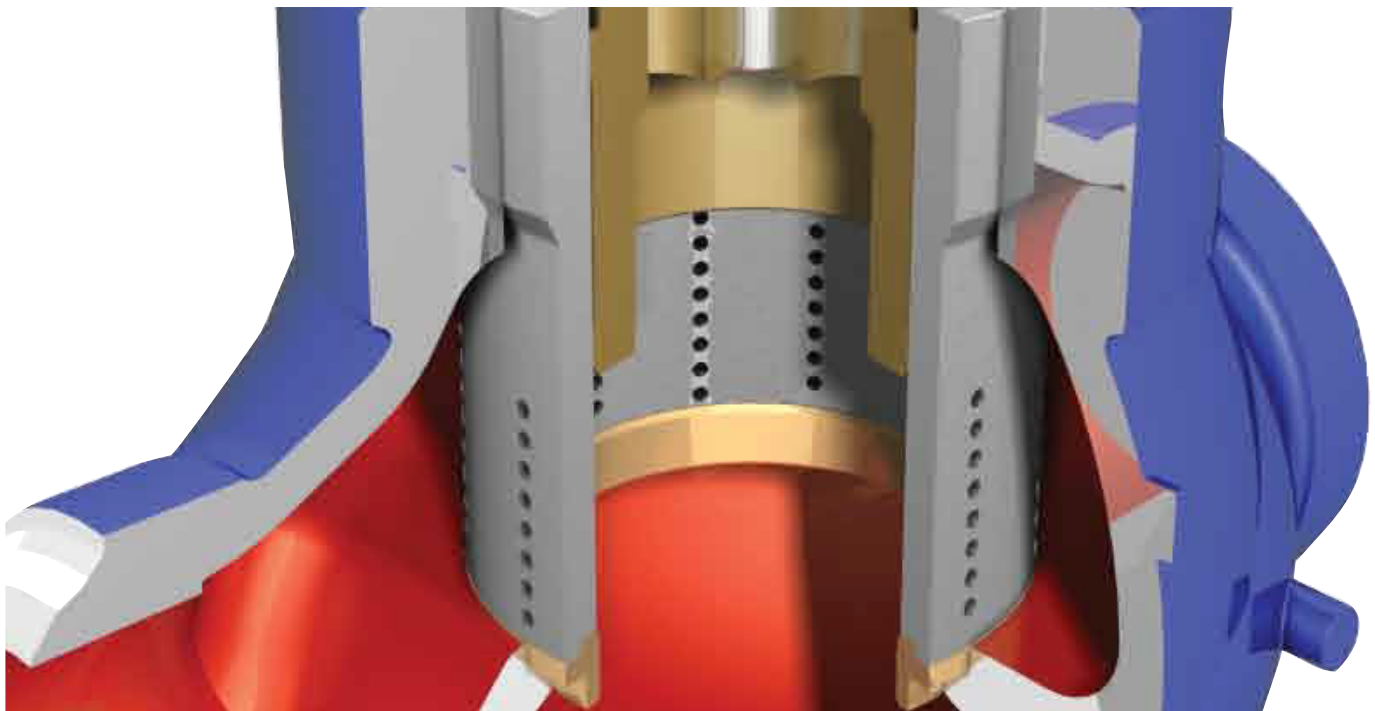
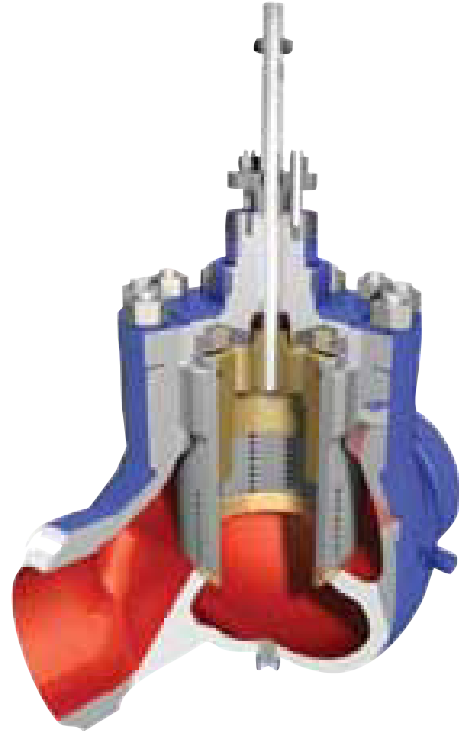

DESCRIPTION

The Trillium Flow Technologies™ cage trim series of control valves BV500/1 and BV990/2, are designed to meet the requirements of most process control applications.

This range of control valves has been developed by Trillium Flow Technologies™ to meet the ever increasing demands of modern day processing plant.

The valves incorporate high integrity features together with a highly flexible philosophy of trim design options. There is a wide range of standard and high duty trims available which can be fitted within the same valve body. The options include 'Multi-Flow', 'Cascade' (2 to 5 stages of letdown), 'X-Stream®' and various designs which can be manufactured to suit the specific application.

At the enquiry stage Trillium Flow Technologies™ will consider the most suitable combination of valve components for each application. Pressure drop, noise, potential for cavitation are all considered to give the most cost effective solution for the particular application.

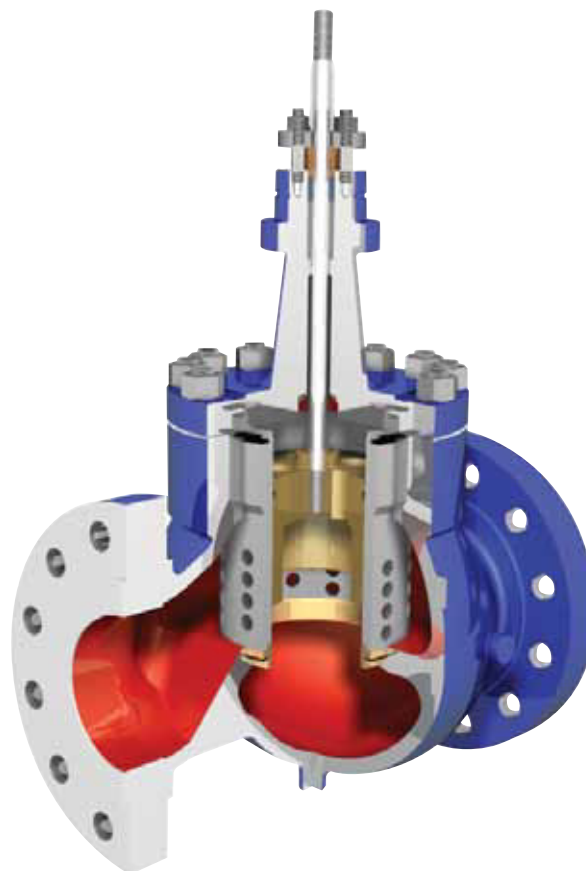

BV500/BV990 Cage Trim Valve
with Multi-Flow cage

DESIGN FEATURES

- Cage guided
- Wide range of trim options
- High stability
- Easy maintenance

PRESSURE RATING

- Class 150 to 4500
- PN10 to PN640

SIZES

- 40mm to 900mm (1 1/2" to 36")

TRAVELS

- 28.5mm to 300mm (1 1/8" to 12")

END CONNECTIONS

- Flanged (all current standards)
- Butt weld
- Socket weld
- Screwed
- Clamped ends
- Hubbed
- Ring Type Joint (RTJ)

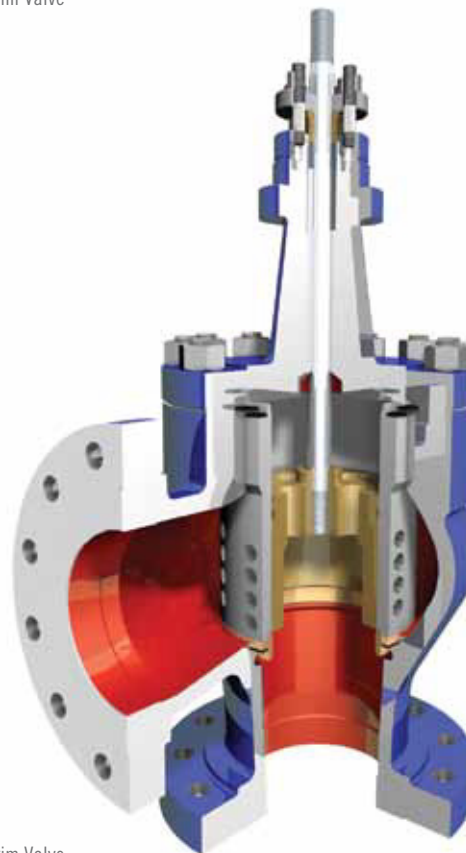

BV501/BV992 Cage Trim Valve
with Multi-Flow cage

VERSATILITY

Trillium Flow Technologies™ Cage Trim Valves offer a wide choice of options to meet most system requirements, eliminating or greatly reducing the multiplicity of valve designs that would otherwise be required.

This flexible range of valves offers an extensive selection of trim designs, materials and sizes, and is therefore able to meet the ever increasing demands of modern day plant. All parts are interchangeable between globe and angle style valves in a given size and pressure rating.

Parts substitution, internal inspection and maintenance are effected with minimum trouble, the essential working components being removable while the body remains undisturbed in the pipeline.

- Simple, low cost, in line maintenance
- Comprehensive interchangeable parts systems
- High-stability plug guiding
- High flow capacity
- Reduced spares inventory

MAIN DESIGN STANDARDS

- ASME B16.34 – Valves-Flanged, Threaded & Welding End
- ASME FCI 70-2 – Control Valve Seat Leakage
- ASME B16.25 – Butt Welding Ends
- ASME B16.5 – Pipe Flanges & Flange Fittings
- NACE MR-01-75 (ISO 15156) Valve Materials (option)
- BS4504 – Circular Flanges for Pipes, Valves & Fittings
- EN12516 – Industrial Valves Shell Design Strength

FEATURES

PRESSURE RATINGS

- ASME Class 150 to 600 (BV500/1 Series)
- ASME Class 900 to 4500 (BV990/2 Series)
- Equivalent metric pressure ratings

BODY

- A choice of globe or angle patterns available
- BV500 & BV990 Globe body
- BV501 & BV992 Angle body

BODY MATERIALS

The Cage Trim series valves can be produced in most forms of castable alloys. Standard body materials are:-

- Carbon steel; Grade WCB, WCC, LCC and LCB
- Stainless steel; Grade 316/304/347
- 1.1/4% chrome moly. steel; Grade WC6
- 2.1/4% chrome moly.steel; Grade WC9
- Monel
- Aluminium Bronze
- Hastelloy B/C
- Duplex / Super duplex

TRIM OPTIONS

- Multi-Flow (MF) – standard
- Cascade (CS) – severe service duties
- Soft faced – for tight shut off
- Variable Stage Cascade (VS)
- Single stage Multi-Flow (SS)
- Flash cone
- X-Stream® (See X-Stream® brochure)

CAGE DESIGNS

MULTI-FLOW (MF) - SINGLE STAGE OF PRESSURE DROP

This form of trim design is fitted as standard and is suitable for most flow control applications. In this design the flow is broken up into multiple jets by a number of radial holes in the cage. The flow is conventionally from outside to inside the trim so that jet impingement/high turbulence levels are controlled within the confines of the valve cage. Impingement of the jets within the valve cage produces a more stable downstream flow, reduces the effect of large scale separation and produces a smaller scale turbulence structure in the valve outlet. This in turn leads to a reduction in acoustic efficiency and changes the power spectrum of the generated noise, both of which contribute to a noise level reduction of between 15 and 20 dBA compared to a contoured or ported trim valve. Further noise reduction in this style of trim can be achieved by reducing the size of the jets in the cage by drilling smaller holes, this design is referred to as the Single Stage Multi-Flow (SS), and can lead to a further 5 dBA reduction in noise level.

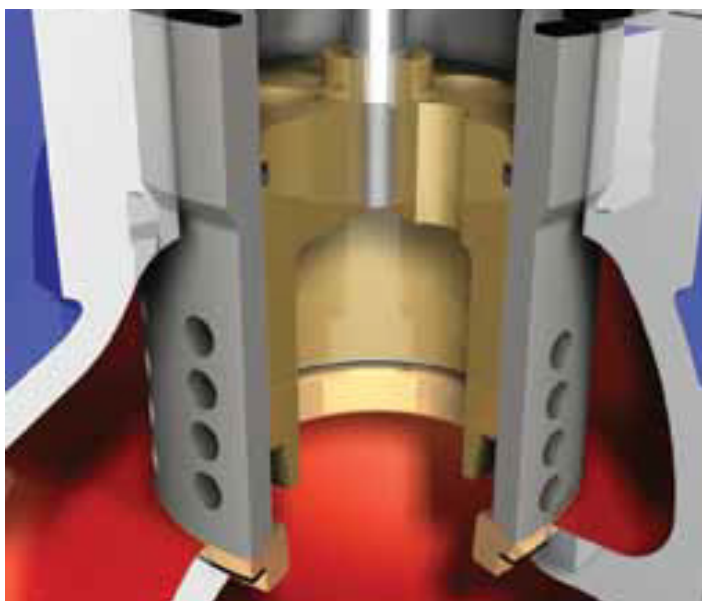

VARIABLE STAGE CASCADE (VS)

Is available when multiple stages of pressure letdown are required at low valve openings. This design particularly suits applications where there is a high-pressure drop at low flows, and a reduced pressure drop at normal to maximum flow-rates. The design philosophy of the Cascade and Multi-Flow Trims designs is combined within this trim.



Variable Stage Cascade

CASCADE (CS)

The Cascade valve trim is a further advancement over the standard Multi-flow valve cage. It is used in control applications where high noise levels or cavitation would be predicted, with a standard trim design. Noise, flow erosion and/or vibration can result in a high pressure drop/ratio application if attention to controlling the pressure drop is not considered. The cascade trim has been specifically designed to eliminate these problems at source by controlling the pressure drop through a number of discrete stages of let-down. The Cascade cage is manufactured to close tolerances and consists of a series of sleeves. The number of sleeves (stages of let-down) required depends upon the amount of treatment necessary for the particular application. Each successive sleeve has a number of radial holes and a carefully calculated increase in flow area to ensure correct apportionment of the pressure drop. Thus, the small radial jets pass through a tortuous flow path resulting in high frictional and impingement losses. At the same time the impingement of the jets onto the outer radially drilled sleeves controls the shock wave formation which has a major influence on overall noise reduction in gas/vapour applications.

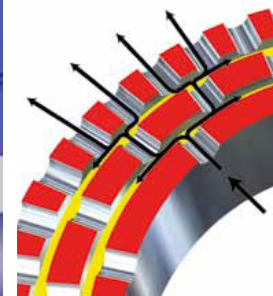
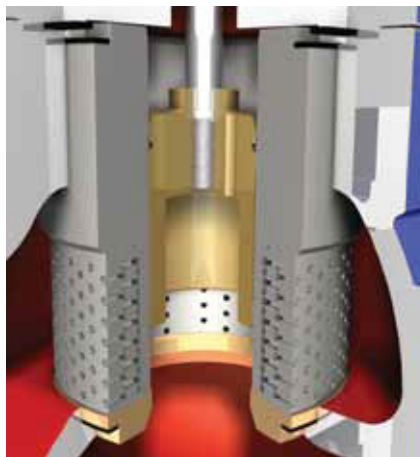

Typical Cascade flow path

BODY PROTECTION UNIT

This design option is utilised on flashing liquid, multi-phase fluids, and on contaminated gas/vapour flows. The unit is designed to prevent erosive outlet flow, from the valve seat, directly impinging onto the pressure containing body walls.

It is manufactured from hardened or hard-faced material to reduce erosion rates. The design breaks the erosive fluid flow into small jets and directs the bulk of the flow towards the valve outlet.



Body Protection Unit

PLUG DESIGNS

BALANCED

The balanced plug design is utilised to greatly reduce fluid forces acting on the valve plug allowing economical actuation and stable control. The cylindrical plug head is drilled with balancing ports to admit pressure above the plug head. The annular leakage flow between the valve plug and cage is minimised by a sealing ring retained within a plug groove. The standard sealing rings are carbon graphite which give Class III leakage. Alternatively a 'U' seal can be fitted to give either Class IV or Class V leakage dependent on seating load applied by the actuator.



Balanced Plug

SOLID (UNBALANCED)

The design is used on relatively low-pressure drop and/or on-off applications. It generally requires the use of much larger actuators than would be required on the balanced plug design and in all but small valve sizes is not suited to control applications.

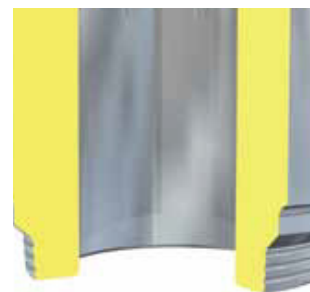

Flash Cone Trim

FLASH-CONE

This plug design is specified on applications requiring a very high rangeability. At low openings the conical plug nose fits inside a matching conical seat. The plug nose has a number of circumferential grooves, which produce a staging of the pressure drop as the flow passes through the small annular passage between the plug and the valve seat. In addition to the increased rangeability this trim also allows the valve to handle higher pressure drops at low valve openings than can be adequately handled by a standard plug design.

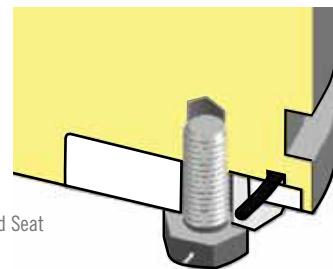

Soft Faced Seat

SEAT DESIGNS

SOFT SEAT

Is specified on applications where it is desirable to have a maximum closure on the control valve. The soft seat design consists of a resilient seal ring clamped into the plug by a face ring. When the soft seat contacts the valve seat, a lip on the seat bites into the face of the seal and effectively prevents leakage through the seat. The soft seat design can be specified in both balanced and un-balanced designs.

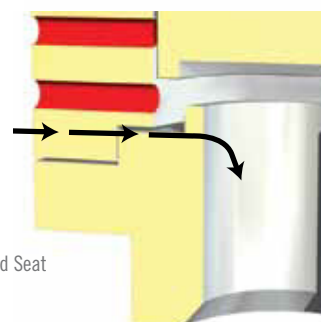

Protected Seat

PROTECTED SEAT

On flashing or contaminated fluid applications protected seat designs can be applied to extend the life of the trim seat area. The special plug head contour ensures that the seating face of the plug is protected from the flow area by an extended lip on the outside of the plug nose. Additionally the use of the protected seat design ensures a deadband before flow starts to pass through the cage. This ensures a reduced velocity through the trim and consequently a reduced rate of erosion.

SEAL RINGS

On balanced design valves the valve plug is designed to incorporate a seal ring which prevents leakage around the periphery of the valve plug. Depending upon the desired leakage and temperature through the valve a variety of seal rings are specified.

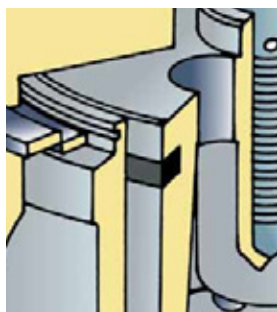

Carbon Ring

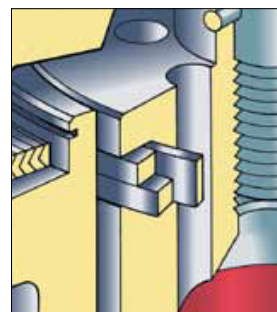

Triple Seal Ring

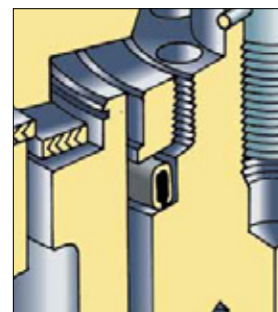

'U' Seal

TABLE 1 – MATERIALS OF CONSTRUCTION

CAGE	PLUG	PLUG STEM	SEAT	SERVICE
420 ST.ST. Hardened	17-4PH ST.ST. Hardened	316 ST.ST./17.4 PH	Integral with Cage/ 316 ST.ST./316 + Stellite	-35°C to 399°C -30°F to 750°F
420 ST.ST. Hardened	316 ST.ST. with Stellite face & Guide			400°C to 565°C 750°F to 1050°F
316 ST.ST. 17-4PH ST.ST.	316 ST.ST. with Chrome Plated Guide Diameter			NACE MR-01-75 -35°C to 232°C -30°F to 450°F
4	1 Hardened with PTFE Face			316 ST.ST.
Monel K500	Monel 400	Monel 400/ Monel K500	Integral with Cage/ Monel K500	-35°C to 500°C -30°F to 932°F
Hastelloy C	Hastelloy C	Hastelloy C	Integral with Cage/Hastelloy C	
Duplex	Duplex/Duplex + Stellite	Duplex	Integral with cage/Duplex	
420 ST.ST. + Tungsten Carbide	316 ST.ST. + Tungsten Carbide	316 ST.ST.	316 ST.ST. + Tungsten Carbide	High Dp

*Options for Stellite face or full Stellite available for most materials.

TABLE 2 – CONTROL VALVE LEAK RATES IN ACCORDANCE WITH ASME/FCI 70-2 (IEC 60534-4)

LEAKAGE CLASS	SEAL RING MATERIAL	TEMPERATURE
Class III	Carbon Graphite	-35°C (-30°F) to 565°C (1050°F)
Class IV & V	Carbon PTFE 'U' Seal	-35°C (-30°F) to 260°C (500°F)
Class IV & V	High temp 'U' Seal	260°C (500°F) to 350°C (660°F)
Class IV	Carbon Triple Seal	350°C (660°F) to 565°C (1050°F)
Class V	Metallic	260°C (500°F) to 600°C (1110°F)
Class VI	Soft Face Sea	-35°C (-30°F) to 232°C (450°F)
Class III, IV & V	None (un-balanced)	Cryogenic to 600°C (1110°F)

TABLE 3 – RECOMMENDED LIMITING VELOCITIES

METRIC UNITS			US UNITS			
BODY SIZE	MM	LIQUID M/S	STEAM OR GAS M/S	BODY SIZE (IN)	LIQUID FT/S	STEAM OR GAS FT/S
40, 50		13.5	150	1½, 2	44	490
80, 100		13.5	150	3, 4	44	490
150, 200, 250, 300		13.5	150	6, 8, 10, 12	44	490
350, 400, 450, 500		12	130	14, 16, 18, 20	39	425
≥600		8.5	120	≥24	28	390

Note: Maximum outlet velocity (steam or gas) = 0.65 x sonic

TABLE 3 – RECOMMENDED LIMITING VELOCITIES

BODY SIZE		MF1 & MF2 SS1 & SS2	MF3 & MF4 SS3 & SS4	MF5 & MF6 SS5 & SS6	MF7 & MF8 SS7 & SS8
MM	IN				
40 to 80	1½ to 3	50:1	45:1	30:1	20:1
100 to 200	4 to 8	65:1	55:1	45:1	35:1
250 to 400	10 to 16	70:1	65:1	55:1	45:1
450 to 750	18 to 30	80:1	70:1	60:1	50:1

Note: Control at openings of less than 5% is not recommended for prolonged periods

TABLE 5 – BV500 GLOBE VALVES & BV501 ANGLE VALVES - MULTI-FLOW TRIM DESIGN CV

SIZE		BONNET MOUNT MM	TRAVEL MM	MF1		MF2		MF3		MF4		MF5	
IN	MM			MOD=%	LIN	=%	LIN	=%	LIN	=%	LIN	=%	LIN
1 1/2	40	54	28.5			32	34	19	22				
2	50	54	28.5	52	55	37	41	20	23				
3	80	71	38	120	130	92	115	68	90	36	50		
4	1	71	38			160	190	130	160	96	120	50	65
		90	57	200	220								
6	150	90	57			360	395	300	335	220	255	120	140
		90	89	410	460								
8	200	90	89			660	700	565	620	430	485	240	275
		127	127	725	780								
10	250	127	89			900	1050	750	915	550	700	290	390
		127	127	1050	1135								
12	300	127	89					1050	1250	750	950	400	520
		127	127			1200	1475						
		127	152	1450	1600								
14	350	127	127									980	1100
		127	152							1750	1900	1400	1600
		127	178					1900	2110				
16	400	127	89									910	1010
		127	127							1750	1900	1400	1600
		127	152			2100	2325	1940	2200				
		127	178	2500	2750								
18	450	127	127									1550	1750
		127	152							1830	2100		
		127	178					2170	2450				
		127	254			3100	3500						
20	500	127	127									1550	1750
		127	152							1830	2100		
		127	178					2170	2450				
		127	254	3750	4000	3100	3500						
24	600	127	152							2500	2800		
		127	178					3330	3500				
		127	254			4600	5000						
		127	305	5400	5800								

Note: Quoted design Cv's for angle valves may be slightly altered due to the valve body style.

TABLE 6 – BV500 GLOBE VALVES & BV501 ANGLE VALVES WITH CASCADE TRIMS – LIQUID FLOW OVER

SIZE IN (MM)	BNT MT MM	TVL MM	CS2		CS2.1		CS2.2		CS2.3		CS3		CS3.1		CS3.2		CS3.3		CS4		CS4.1	
			=%	LIN	=%	LIN	=%	LIN	=%	LIN	=%	LIN	=%	LIN	=%	LIN	=%	LIN	=%	LIN	=%	LIN
1½ (40)	54	28.5			14	20	6	12					10	18	6	10					4	8
2 (50)	54	28.5			14	22	6	12					12	18	6	10					4	8
3 (80)	71	38			28	46	14	24					24	38	12	20					10	16
	90	57	44	65							36	56							16	24		
4 (100)	71	38			32	52	16	26					26	44	12	22					12	18
	90	57	58	90							48	75							20	34		
6 (150)	90	57			90	145	46	75					75	120	38	60					32	52
	90	89	130	205							110	175							48	80		
8 (200)	90	89					170	280	85	145					140	230	70	120				
	127	127			260	395							215	340							185	290
	127	152	295	440							245	380							215	330		
10 (250)	127	89					269	401	180	320					185	248	141	141	92	124	56	62
	127	127			383	554							265	354					132	177	66	88
	127	152	460	665							320	425							160	212	80	106
12 (300)	127	89							240	420							155	235	85	112	66	78
	127	127					336	506							235	312						
	127	152			567	821							335	446					167	223	83	112
	127	178	660	960							470	625							235	312	117	156
14 (350)	127	89					370	470	250	300					250	340	170	280				
	127	152			600	920							350	450								
	127	178	900	1100							450	550										
16 (400)	127	89							250	350							170	280				
	127	127					410	505							250	340						
	127	152			1000	1150							350	450								
	127	178	1250	1325							450	550										
18 (450)	127	152					1000	1150	700	800					500	550	400	420				
	127	178			1250	1325							620	710								
	127	254	1500	1750							750	800										
20 (500)	127	152					1200	1400	900	1000					600	700	450	520				
	127	178			1400	1750							700	800								
	127	254	1750	2000							800	980										
24 (600)	127	178					1600	1750	1100	1400					800	850	600	650				
	127	254			2300	2500							1100	1250								
	127	305	2700	2900							1300	2450										

TABLE 7 – BV500 GLOBE VALVES & BV501 ANGLE VALVES WITH CASCADE TRIMS – GAS FLOW UNDER

SIZE IN (MM)	BNT MT MM	TVL MM	CS2		CS2.1		CS2.2		CS2.3		CS3		CS3.1		CS3.2		CS3.3		CS4		CS4.1	
			=%	LIN	=%	LIN	=%	LIN	=%	LIN	=%	LIN	=%	LIN	=%	LIN	=%	LIN	=%	LIN	=%	LIN
1½ (40)	54	28.5			14	22	8	12					14	20	6	12					4	8
2 (50)	54	28.5			16	24	8	12					14	22	6	12					4	8
3 (80)	71	38			32	50	16	26					30	46	14	24					10	18
	90	57	48	70							42	65							16	26		
4 (100)	71	38			36	58	18	30					34	54	16	28					12	20
	90	57	65	95							58	90							22	36		
6 (150)	90	57			100	155	52	80					90	140	46	75					34	56
8 (200)	90	89	145	225							130	205							50	85		
	90	89					190	305	95	160					170	275	85	145				
	127	127			285	425							260	395							185	305
10 (250)	127	152	320	470							295	440							225	340		
	127	89					295	495	200	450					140	180			100	140	50	68
	127	127			410	550							265	354					132	177	66	88
12 (300)	127	152	485	850							320	425							160	212	80	106
	127	89							370	470					235	312			117	156	60	78
	127	127					470	625											130	180	70	95
	127	152			550	850							335	416					167	223	83	112
14 (350)	127	178	600	1000							470	625							235	312	117	156
	127	89							250	300							170	280				
	127	127					370	470							250	340						
	127	152			600	920							350	450								
16 (400)	127	178	900	110							450	550										
	127	89							250	350							170	280				
	127	127					410	505							250	340						
	127	152			1000	1150							350	450								
18 (450)	127	178	1250	1325							450	550										
	127	152					1000	1150	700	800					500	550	400	420				
	127	178			1250	1325							620	710								
20 (500)	127	254	1500	1750							750	800										
	127	152					1200	1400	900	1000					600	700	450	520				
	127	178			1400	1750							700	800								
24 (600)	127	254	1750	2000							800	980										
	127	178					1600	1750	1100	1400					800	850	600	650				
	127	305	2700	2900							1300	2450										

TABLE 8 – BV990 MULTI-FLOW TRIM DESIGN CV

SIZE		TRAVEL	M F 1			M F 2		M F 4		M F 6	
IN	MM	MM	MOD=%	=%	LIN	=%	LIN	=%	LIN	=%	LIN
1 1/2	40	28.5		30	30	20	20	14	14	8	8
2	50	28.5		38	45	32	32	23	23	13	13
3	80	38		84	100	72	72	50	50	29	29
4	100	57	160	155	165	130	130	90	90	52	52
6	150	57			360	280	280	195	195	112	112
		89		400	450						
8	200	89		550	620	520	520	365	365	210	210
		127	600		700						
10	250	89		830	830	750	750	525	525	300	300
		127	900		1050						
12	300	89						770	770	440	440
		127			1200						
		178									
14	350	127						770	770	440	440
		178		1940	2200	1600	1600	1400	1400	1200	1200
16	400	89								770	770
		127						1200	1200		
		178	2000				2200	1750	1750	1400	1400
18	450	127						1400	1400	1200	1200
		178								1750	1750
		254		2800	3000	2200	2800	2200	2200		
20	500	127								1200	1200
		178						1750	1750		
		254			3750	3100	3100	2800	2800	2200	2200
24	600	178								1750	1750
		254						3100	3100	2800	2800
		305			4750	5190	3900	3900	3900		

TABLE 9 – BV992 MULTI-FLOW TRIM DESIGN CV

SIZE		TRAVEL	M F 1			M F 2		M F 4		M F 6	
IN	MM	MM	MOD=%	=%	LIN	=%	LIN	=%	LIN	=%	LIN
1 1/2	40	28.5		30	30	20	20	14	14	8	8
2	50	28.5		38	45	32	32	23	23	13	13
3	80	38		84	100	72	72	50	50	29	29
4	100	57	160	155	165	130	130	90	90	52	52
6	150	57			360	280	280	195	195	112	112
		89		400	450						
8	200	89		550	620	520	520	365	365	210	210
		127	600		800						
10	250	89		830	830	750	750	525	525	300	300
		127	900		1100						
12	300	89						770	770	440	440
		127									
		178	1750		1700						
14	350	127						770	770	440	440
		178		1940	2200	1600	1600	1400	1400	1200	1200
16	400	89								770	770
		127						1200	1200		
		178		2500	2750	2200	2200	1750	1750	1400	1400
18	450	127						1400	1400	1200	1200
		178								1750	1750
		254		3100	3500	2800	2800	2200	2200		
20	500	127								1200	1200
		178						1750	1750		
		254		3750	4430	3100	3100	2800	2800	2200	2200
24	600	178								1750	1750
		254						3100	3100	2800	2800
		305			4750	5190	3900	3900			

TABLE 10 - BV990 AND BV992 CASCADE TRIMS FLOW UNDER AND OVER

SIZE		TRAVEL	CS2		CS 2.1		CS2.2		CS2.3		CS3		CS3.1		CS3.2		CS3.3	
IN	MM	MM	=%	LIN	=%	LIN	=%	LIN	=%	LIN	=%	LIN	=%	LIN	=%	LIN	=%	LIN
1 1/2	40	28.5	10	12	7	8					10		7	8				
2	50	28.5			7	8							7	8				
		38	20	33		20	10	12			10	20		12				
3	80	38	40	48	30	36		24			20	24	15	12				
		57	60	72		60					36	36	30	30				
4	100	57	60	96	48	72	32	48	15	32	48	48	24	36	12	24	9	12
6	150	57			108	144	84	112	54	72			54	72	42	56	27	36
		89	168	224							84	112						
8	200	89	200	263	168	224		112		65					100		35	
		127			282	360												
10	250	152	340	450	140		70		35		170	225	140	188	70	9		47
		89	370	495	185	248	92	124	46	62								
12	300	152	640	850	320	425												
		89	200															
		152		950							500	830						

TABLE 11 – END CONNECTION DETAILS FOR BUTT WELD END VALVES (MM)

SIZE		BV500 – ALL RATINGS		BV990 – UP TO & INCLUDING 1500 (PN 250)		BV990 – 2000 RATING (PN 330)		BV990 – 2500 RATING (PN 420)	
IN	MM	ID	OB	ID	OD	ID	OD	ID	OD
1 1/2	40	20	70	38	89	38	89	38	89
2	50	38	80	38	85	38	95	38	95
3	80	65	105	65	115	75	130	75	145
4	100	90	145	85	155	85	145	90	185
6	150	145	200	140	205	125	235	130	265
8	200	185	255	190	310	200	340	195	350
10	250	250	315			255	390	225	450
12	300	300	370			325	515		
16	400	370	460						
20	500								
24	600								
30	750								

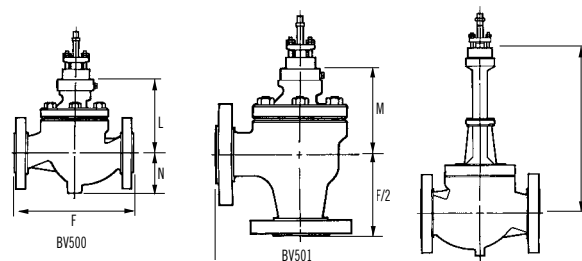

TABLE 12 – BV500/1 SERIES VALVES DIMENSIONS

VALVE SIZE	IN	1 1/2	2	3	4	6	8	10	12	14	16	18	20	24	30
MM	40	50	80	100	150	200	250	300	350	400	450	500	600	750	
Up to ASME 300 Class RF and BS4504	F	9 1/4	10 1/2	12 1/2	14 1/2	18 3/8	22 3/8	28 1/4	30 1/2	41 3/8	41 3/8	47	54	60	66
		235	267	317	368	473	568	718	775	1057	1057	1194	1372	1524	1676
Up to ASME 300 Class RTJ		9 3/4	11 1/8	13 1/8	15 1/8	19 1/4	23	28 7/8	31 1/8	42 1/4	42 1/4	47 5/8	54 5/8	60 5/8	66 5/8
		248	283	333	384	489	584	733	791	1073	1073	1210	1388	1540	1692
Class 300 Butt Weld		9 7/8	11 1/4	13 1/4	15 1/2	20	24	30	30 1/2	41 3/8	41 3/8	47	54	60	66
		251	286	337	394	508	610	762	775	1057	1057	1194	1372	1524	1676
BS, PN64, PN100, ASME 600 Class RF Flanged & Butt Weld		9 7/8	11 1/4	13 1/4	15 1/2	20	24	30	32 1/4	43 3/8	43 3/8	49 1/4	60	63	70
		251	286	337	394	508	610	762	820	1108	1108	1251	1524	1600	1778
ASME 600 Class RTJ		9 7/8	11 3/8	13 3/8	15 5/8	20 1/8	24 1/8	30 1/8	32 3/8	43 3/4	43 3/4	49 3/8	60 1/8	63 1/8	70 1/8
		251	289	340	397	511	613	765	823	1111	1111	1254	1527	1603	1781
Standard Bonnet (L)		5 15/16	5 9/16	7 9/16	7 5/8	9 15/16	13 3/16	18 11/16	20 3/16	23 3/8	23 3/8	37 7/8	37 7/8	43 1/8	CF
		148	148	185	193	252	335	475	513	721	721	963	963	1114	
Standard Bonnet (M)		4 7/8	4 7/8	5 1/2	6 5/16	7 7/16	9 9/16	CF	CF	CF	CF	CF	CF	CF	CF
		124	124	140	160	189	237								
Normalising Bonnet (L)		10 11/16	10 11/16	11 3/4	12 1/16	14 7/16	18	25 3/4	28 1/2	41 3/8	41 3/8	52	52	59	CF
	272	272	298	306	368	457	655	724	1057	1057	1321	1321	1499		
Normalising Bonnet (M)	9 3/4	9 3/4	9 15/16	10 3/4	12	14 1/8	CF	CF	CF	CF	CF	CF	CF	CF	
	248	248	253	273	305	359									
Bellows Bonnet (L)	13 9/16	13 9/16	16 15/16	16 15/16	22 9/16	30 1/16	32	33 9/16	CF	CF	CF	CF	CF	CF	
	344	344	430	430	572	763	815	853							
Bellows Bonnet (M)	12 5/8	12 5/8	15 5/8	15 5/8	20 1/16	26 3/16	CF	CF	CF	CF	CF	CF	CF	CF	
	320	320	397	397	509	665									
Extension Bonnet (L)	17 1/4	17 1/4	17 15/16	17 15/16	21 5/8	25 3/8	35 7/8	CF	CF	CF	CF	CF	CF	CF	
	438	438	455	455	550	645	910								
Extension Bonnet (M)	16 5/16	16 5/16	16 9/16	16 9/16	20 1/8	21 1/2	CF	CF	CF	CF	CF	CF	CF	CF	
	414	414	421	421	511	546									
N	3 1/2	3 5/8	4 11/16	5 5/16	6 3/4	8 1/2	10 5/8	12 1/8	16	16	18 5/8	18 5/8	21 5/8	CF	
	89	92	119	135	172	216	270	308	406	406	473	473	543		
Standard Travel	1 1/8	1 1/8	1 1/2	1 1/2	2 1/4	3 1/2	3 1/2 min	3 1/2 min	7	7	10	10	12	CF	
	28.5	28.5	38	38	57	89	89	89	178	178	254	254	305		

EXTENDED TRAVELS FOR CASCADE TRIM VALVES

Extended travel	1 1/2	1 1/2	2 1/4	2 1/4	3 1/2	6	6	7	CF	CF	CF	CF	CF	CF
	38	38	57	57	89	152	152	178						
Bonnet Mount Dia	2 15/16	2 15/16	3 9/16	3 9/16	3 9/16	5	5	5	CF	CF	CF	CF	CF	CF
	71	71	90	90	90	127	127	127						
Standard L	8 1/8	8 1/8	10 9/16	9 7/8	13 5/16	18 5/8	22	26	CF	CF	CF	CF	CF	CF
	207	207	268	251	338	473	555	650						
Normalising L	12 3/4	12 3/4	16	15 15/16	18 15/16	24	30	34 1/2	CF	CF	CF	CF	CF	CF
	324	324	400	386	478	600	765	877						

Note: Flange valves are generally in accordance with ISA 75.08.06 and ISA 75.08.01. CF = Consult Factory.

TABLE 13 – BV990 SERIES VALVES DIMENSIONS

VALVE SIZE	IN	1/2	2	3	4	6	8	10	12	14	16	18	20	24	30	
	MM	40	50	80	100	150	200	250	300	350	400	450	500	600	750	
RATINGS UP TO & INCLUDING ASME CLASS 1500																
ASME 900 RF & PN160	F	12	13 1/4	15 1/2	18 1/2	21 7/8	36 3/4	36	44 1/2	56	56	68	68 1/2	CF	CF	
		305	337	394	470	556	934	914	1130	1422	1422	1727	1740			
ASME 900 RTJ		12	13 3/8	15 5/8	18 5/8	22	36 7/8	36 1/8	44 1/2	56	56	68	68 1/2	CF	CF	
		305	340	397	473	559	937	918	1130	1422	1422	1727	1740			
ASME 1500 RF & PN250		12	13 1/4	16 1/4	19 1/4	24	39	45	45 1/8	55 1/4	56	68	68 1/2	CF	CF	
		305	337	413	489	610	990	1142	1146	1404	1422	1727	1740			
ASME 1500 RTJ		12	13 3/8	16 3/8	19 3/8	24 1/4	39 3/8	45 3/8	45 1/8	55 1/4	56 5/8	68	68 1/2	CF	CF	
		305	340	416	492	616	1001	1153	1146	1404	1440	1727	1740			
ASME 900 & 1500 PN160 & PN250 Butt Weld		12	13 1/4	16 1/4	19 1/4	24	39 3/8	45	45 1/8	56	56	68	68 1/2	CF	CF	
		305	337	413	489	610	1001	1142	1146	1422	1422	1727	1740			
Standard Bonnet		L	7 7/8	8 1/2	9 3/8	11 3/4	11 7/8	19 5/8	23 3/4	26 3/4	28 3/4	28 3/4	37	41 1/2	CF	CF
			200	215	238	298	302	498	602	680	730	730	940	1054		
Normalising Bonnet			12 5/16	12 7/8	14	16	16 5/16	27 3/8	29 1/2	31 1/2	35 1/2	35 1/2	43 1/2	49 1/4	46 3/8	CF
			313	327	355	406	415	695	750	800	902	902	1105	1250	1178	
N			3 3/8	3 3/4	5	5 7/8	7 3/8	11 1/4	12 3/8	13	13 1/2	13 1/2	17 3/4	19 5/8	22 7/8	CF
			86	95	126	149	188	286	315	330	342	342	451	500	582	
Standard Travels	1 1/8		1 1/8	1 1/2	2 1/4	2 1/4	3 1/2	3 1/2	Refer to trim selection							
	28.6		28.6	38	57	57	89	89								
Bonnet Mount Dia	2 1/8		2 1/8	2 13/16	3 9/16	3 9/16	3 9/16	5	5	5	5	5	5	5	5	
	54		54	71	90	90	90	127	127	127	127	127	127	127	127	
ASME CLASS 2000																
ASME 2000 Butt Weld	F		12	14 1/4	20	24	32	39	44 15/16	52	CF	CF	CF	68	CF	CF
			305	368	508	610	813	990	1142	1321				1727		
Standard Bonnet			7 7/8	8 9/16	9 7/8	12 1/8	13 3/4	19 5/8	22 3/4	26 1/4	CF	CF	CF	33 7/8	CF	CF
			200	217	251	309	350	499	603	667				859		
Normalising Bonnet			12 5/16	13 9/16	15 1/8	16 5/8	20	27 3/8	31 1/2	34 1/8	CF	CF	CF	CF	CF	CF
		313	344	385	422	507	696	800	867							
N		3 3/8	4 1/16	5	6 1/16	9 1/4	11 1/4	13 3/8	15 5/8	CF	CF	CF	CF	CF	CF	
		86	103	128	154	235	286	339	397							
Travel		1 1/8	1 1/8	1 1/2	2 1/4	2 1/4	3 1/2	3 1/2	Refer to trim selection							
		28.6	28.6	38	57	57	89	89								
Bonnet Mount Dia		2 1/8	2 1/8	2 13/16	3 9/16	3 9/16	3 9/16	5	5	5	5	5	5	5	5	
		54	54	71	90	90	90	127	127	127	127	127	127	127	127	
ASME CLASS 2500																
ASME 2500 Butt Weld		F	14 1/8	16 1/4	21 1/2	25 5/8	35 7/16	45 1/4	55 1/8	63	71	CF	CF	CF	CF	CF
			359	413	546	650	900	1150	1400	1600	1803					
Standard Bonnet			8 7/8	10 1/4	11 5/8	15	20 1/4	25 1/2	CF	CF	CF	CF	CF	CF	CF	CF
	225		260	296	381	514	649									
Normalising Bonnet	14		14 7/8	16 5/8	19 7/8	26 3/8	45 1/4	CF	CF	CF	CF	CF	CF	CF	CF	
	355		377	422	504	669	846									
N	4		4 3/8	5	7	9 3/8	12 3/8	CF	CF	CF	CF	CF	CF	CF	CF	
	100		110	128	177	238	315									
Travel	1 1/8		1 1/8	1 1/2	2 1/4	2 1/4	3 1/2	3 1/2	Refer to trim selection							
	28.6		28.6	38	57	57	89	89								
Bonnet Mount Dia	2 13/16		2 13/16	3 9/16	3 9/16	3 9/16	5	5	5	5	5	5	5	5	5	
	71		71	90	90	90	127	127	127	127	127	127	127	127	127	

CF = Consult Factory Consult factory for ASME Class 4500 Rated Valves

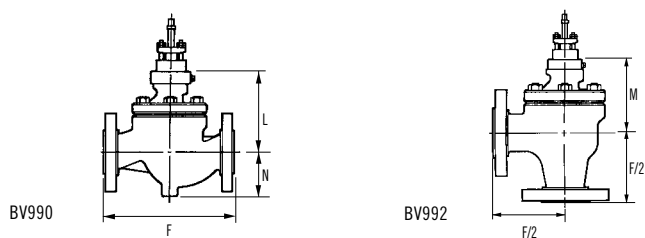

TABLE 14 – BV992 SERIES VALVES DIMENSIONS

VALVE SIZE	IN	1 1/2	2	3	4	6	8	10	12	14	16	18	20	24	30
	MM	40	50	80	100	150	200	250	300	350	400	450	500	600	750
RATINGS UP TO & INCLUDING ASME CLASS 1500															
ASME 900 RF & PN160	F/2	6	7	8 1/8	9 1/4	12 13/16	CF	CF	CF	CF	CF	CF	CF	CF	CF
		152	178	206	235	310									
ASME 900 RTJ	F/2	6	7 1/16	8 13/16	9 5/16	12 1/4	CF	CF	CF	CF	CF	CF	CF	CF	CF
		152	179	208	237	311									
ASME 1500 RF & PN250	F/2	6	7	8 1/2	9 5/8	13 1/4	CF	CF	CF	CF	CF	CF	CF	CF	CF
		152	178	216	244	337									
ASME 1500 RTJ	F/2	6	7 1/16	8 9/16	9 11/16	13 5/16	CF	CF	CF	CF	CF	CF	CF	CF	CF
		152	179	218	246	338									
ASME 900 & 1500 PN160 & PN250 Butt Weld	F/2	6	6 5/8	8 1/2	9 5/8	13 1/4	CF	CF	CF	CF	CF	CF	CF	CF	CF
		152	168	216	244	337									
Standard Bonnet	M	6 7/16	7	7 7/16	9 1/16	CF	CF	CF	CF	CF	CF	CF	CF	CF	CF
		175	178	188	230										
Normalising Bonnet	M	11 3/8	11 7/16	12	13 3/8	CF	CF	CF	CF	CF	CF	CF	CF	CF	CF
		288	290	304	339										
Standard Travels	M	1 1/8	1 1/8	1 1/2	2 1/4	2 1/4	3 1/2	3 1/2	Refer to trim selection						
		28.6	28.6	38	57	57	89	89							
Bonnet Mount Dia	M	2 1/8	2 1/8	2 13/16	3 9/16	3 9/16	3 9/16	5	5	5	5	5	5	5	5
		54	54	71	90	90	90	127	127	127	127	127	127	127	127
ASME CLASS 2000															
ASME 2000 Butt Weld	F/2	6	7 1/4	10	12	16	19 1/4	22 1/4	24 3/4	CF	CF	CF	CF	CF	CF
		152	184	254	305	407	495	565	629						
Standard Bonnet	M	6 7/8	7	7 13/16	9 7/16	12 3/16	16 1/4	CF	CF	CF	CF	CF	CF	CF	CF
		175	178	199	239	310	413								
Normalising Bonnet	M	11 3/8	12	13 1/8	13 7/8	CF	CF	CF	CF	CF	CF	CF	CF	CF	CF
		288	306	333	352										
Travel	M	1 1/8	1 1/8	1 1/2	2 1/4	2 1/4	3 1/2	3 1/2	Refer to trim selection						
		28.6	28.6	38	57	57	89	89							
Bonnet Mount Dia	M	2 1/8	2 1/8	2 13/16	3 9/16	3 9/16	3 9/16	5	5	5	5	5	5	5	5
		54	54	71	90	90	90	127	127	127	127	127	127	127	127
ASME CLASS 2500															
ASME 2500 Butt Weld	F/2	6 7/8	8 1/8	10 3/4	12 13/16	17 3/4	22 5/8	27 9/16	31 1/2	CF	CF	CF	CF	CF	CF
		175	207	273	325	450	575	700	800						
Standard Bonnet	M	CF	CF	CF	CF	CF	CF	CF	CF	CF	CF	CF	CF	CF	CF
Normalising Bonnet	M	CF	CF	CF	CF	CF	CF	CF	CF	CF	CF	CF	CF	CF	CF
Travel	M	1 1/8	1 1/8	1 1/2	2 1/4	2 1/4	3 1/2	3 1/2	Refer to trim selection						
		28.6	28.6	38	57	57	89	89							
Bonnet Mount Dia	M	2 13/16	2 13/16	3 9/16	3 9/16	3 9/16	5	5	5	5	5	5	5	5	5
		71	71	90	90	90	127	127	127	127	127	127	127	127	127

CF = Consult Factory Consult factory for ASME Class 4500 Rated Valves

TABLE 15 – BV500 AND BV501 APPROXIMATE WEIGHTS (KG) WITH MULTI-FLOW CAGES

SIZE		TRAVEL MM	UP TO 300 (PN 40)						600 RATING (PN 100)					
IN	MM		BONNET STYLE											
			STANDARD		NORMALISING		BELLOWS		STANDARD		NORMALISING		BELLOWS	
		FLG	BW	FLG	BW	FLG	BW	FLG	BW	FLG	BW	FLG	BW	
1½	40	28.5	20	18	23	21	30	28	22	18	25	21	32	28
2	50	28.5	21	18	24	21	31	28	30	18	33	21	40	28
3	80	38	58	30	62	34	76	48	60	30	64	34	78	48
4	100	38	67	52	72	58	96	81	88	52	94	58	117	81
6	150	57	148	108	153	114	185	145	179	108	185	114	216	145
8	200	89	230	265	240	275	282	317	305	265	315	275	357	317
		127	270	305	280	315	322	357	350	310	360	320	402	362
10	250	89	470	540	495	565	565	630	620	540	645	565	710	630
		127	494	570	519	595	589	660	650	570	675	595	740	660
12	300	89	612	552	637	577	712	652	800	714	825	739	900	814
		127	666	606	691	631	766	706	863	777	888	802	877	791
		152	666	606	691	631	766	706	863	777	888	802	877	791
14	350	All	1571	1440	1602	1471	1740	1609	1709	1610	1752	1652	CF	CF
16	400	All	1571	1440	1602	1471	1740	1609	1709	1610	1752	1652	CF	CF
18	450	All	2056	1965	2115	2012	CF	CF	2840	2500	2879	2538	CF	CF
20	500	All	2510	2340	2580	2390	CF	CF	3520	3267	3600	3340	CF	CF
24	600	All	4086	3844	4159	3944	CF	CF	5010	4795	5140	4910	CF	CF

CF = Consult factory

TABLE 16 – BV990 AND BV992 APPROXIMATE WEIGHTS (KG) WITH MULTI-FLOW CAGES

SIZE		900 & 1500 RATING (PN 150 & PN 250)				2000 RATING (PN 330)				2500 RATING (PN 420)			
IN	MM	BONNET STYLE											
		STANDARD		NORMALISING		STANDARD		NORMALISING		STANDARD		NORMALISING	
		FLG	BW	FLG	BW	FLG	BW	FLG	BW	FLG	BW	FLG	BW
1½	40	24	20	29	25	NA	24	NA	29	32	27	37	32
2	50	42	34	47	39	NA	42	NA	47	51	43	56	48
3	80	61	50	71	60	NA	57	NA	67	84	70	93	79
4	100	205	177	215	187	NA	197	NA	207	292	242	310	260
6	150	320	279	340	299	NA	430	NA	480	577	495	622	540
8	200	702	655	735	685	NA	805	NA	860	1150	999	1208	1057
10	250	1300	1198	1367	1265	NA	1670	NA	1789	CF	CF	CF	CF
12	300	1800	1655	1900	1755	NA	2098	NA	2199	CF	CF	CF	CF
14	350	CF	CF	CF	CF	NA	CF	NA	CF	CF	CF	CF	CF
16	400	2200	CF	2290	CF	NA	CF	NA	CF	CF	CF	CF	CF
18	450	CF	CF	CF	CF	NA	CF	NA	CF	CF	CF	CF	CF
20	500	CF	CF	CF	CF	NA	CF	NA	CF	CF	CF	CF	CF
24	600	CF	CF	CF	CF	NA	CF	NA	CF	CF	CF	CF	CF

CF = Consult factory

BONNET FORMS

STANDARD

For applications where the temperature of the controlled fluid is between -18°C (0°F) and 232°C (450°F). May be used with graphite packing up to 315°C (600°F). Although modern packagings are suitable for much higher temperatures, it is recommended that the normalising bonnet be fitted in cases where the temperatures exceed the above values to accommodate lagging of the control valve body.

NORMALISING

For protection of the gland packing at temperatures above 232°C (450°F) and below -45°C (-49°F) down to -100°C (-150°F) The bonnet is designed with fins which dissipate the heat from process fluid and help protect the packings and actuator assembly from high temperatures. In addition, the normalising bonnet is longer than the standard bonnet so that the valve can easily be lagged without interference with the actuator.

BELLOWS SEAL

A positive leakproof stem seal for cases where gland leakage cannot be permitted. The standard bellows material is 321 stainless steel, although many other materials are available on request. The design consists of a welded flexible steel bellows which is clamped in an extended bonnet/ bonnet hood. This effectively cuts out any possible leakage path around the plug stem and therefore prevents emissions from the valve packings. Packings are fitted in these valves but only act as a backup to the bellows.

CRYOGENIC

Used for temperatures below -100°C (-150°F). The bonnet designed with a long necked section which distances the packing away from the process fluid. The necked section is designed with a minimum wall section to minimise heat transfer. Cold box extension/cryogenic bonnets are also available.

PACKING

Packings are selected based on fluid temperature and fluid type. The most common packing system materials are PTFE for low temperature and graphite for high temperature. For hydrocarbon service and where emission levels need to be controlled, further types of packings are available.

Packings have been tested to prove emission levels of less than 500 parts per million over 50,000 cycles and under thermal cycling conditions.

PTFE CHEVRON

Used for applications where the temperature is between cryogenic and 232°C (450°F)

GRAFOIL

Used on high temperature applications where the temperature exceeds 232°C (450°F)

Other packing types can be accommodated as required.

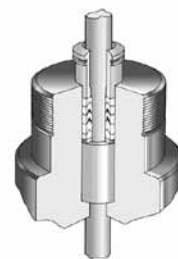

PTFE Chevron

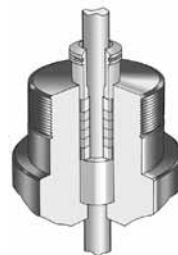

Grafoil

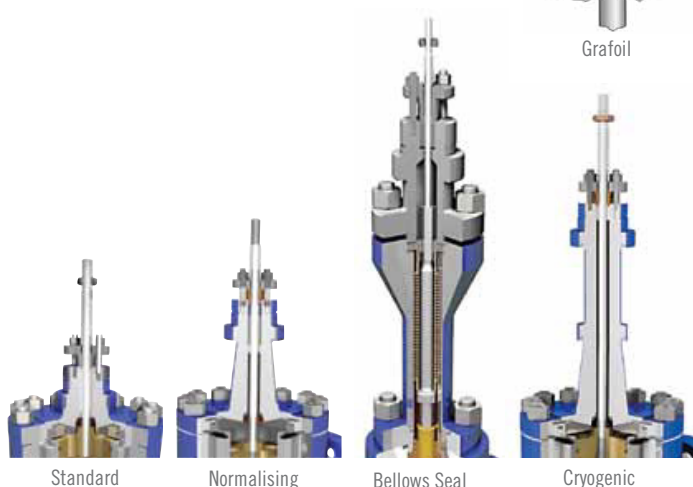

Standard

Normalising

Bellows Seal

Cryogenic

SILENCERS

SILENCERS/DYNAMIC ATTENUATOR

This equipment is used on gas/vapour services to control fluid velocity and to produce dynamic attenuation. Each silencer is designed for its specific application and is considered in conjunction with the selection of the upstream control valve/trim. In selecting the silencer design, all operating conditions are considered to ensure acceptable performance.

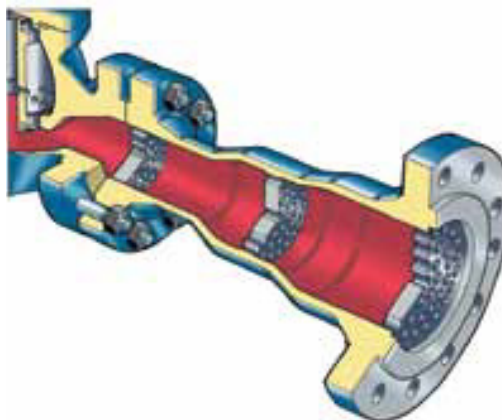

CHARACTERISTICS

LINEAR

This characteristic provides a flow rate which is directly proportional to the valve lift. The proportional relationship produces a characteristic with a constant slope, so that with constant pressure drop the valve gain will be the same at all flows. The linear valve plug is commonly specified for liquid level control and for flow control applications requiring constant gain.

EQUAL PERCENTAGE

Equal increments of valve lift produce equal percentage changes in the fluid flow. The change in flow rate is always proportional to the flow rate just before the change in plug position is made. The equal percentage characteristic is generally used on pressure control applications, and on other applications where a large percentage of pressure drop is normally absorbed by the system itself. Valves with this characteristic should also be considered where highly varying pressure drop conditions occur or high rangeability is required.

QUICK OPENING

This provides for maximum change in flow rate at low valve lifts with a fairly linear relationship. Additional increases in valve lift give sharply reduced changes in flow rate. When the valve plug nears the wide open position, the change in flow rate approaches zero.

INTERMEDIATE

Other intermediate or special characteristics are available on request to meet specific control requirements.

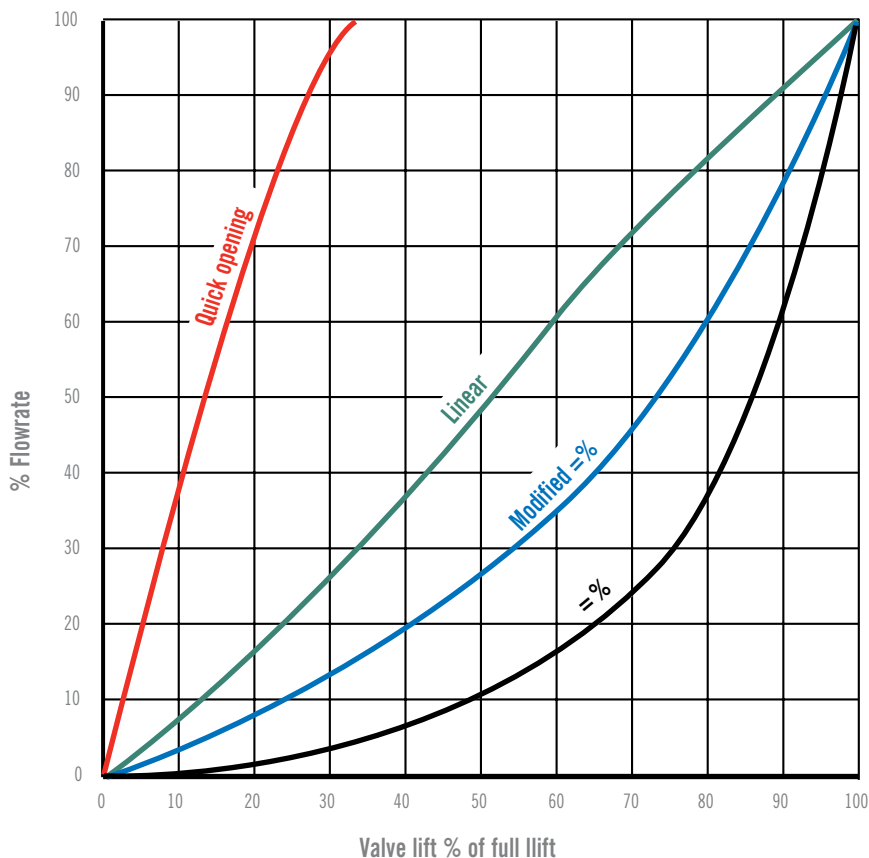

VALVE SERVICES

SITE SERVICE	WORKSHOP SERVICES	SERVICE PLANS
Outage, shutdown and turnaround management	Mechanical valve overhaul and refurbishment	24hr Customer Service Number
Overhaul and refurbishment	Valve pressure testing	48hr Service Response Engineer
Installation and commissioning	Upgrades and modifications	LTSA (Long Term Service Agreement)
In-situ valve seat replacement	Control valve service, maintenance and monitoring	Embedded engineering programmes
In-situ testing and monitoring	Actuator servicing and torque testing	Asset management
Turnkey project management	Service exchange programmes for valves and actuators	Bespoke service management





Trillium Flow Technologies UK Limited

Britannia House Huddersfield Road,
Elland West Yorkshire HX5 9JR, United Kingdom
T: +44 (0) 1422 282 000;
F: +44 (0) 1422 282 100;
E: controlvalves@trilliumflow.com

TRILLIUMFLOW.COM